



Crop Drying & Storage Products



**DRIVE OVER DRYING FLOORS
and MAIN AIR DUCTS**



www.lingward.com



TIMBER DRIVE OVER DRYING FLOORS

Designed to ventilate a wide range of bulk cereals and root crops. The top boards are machined from a hard wearing durable hardwood and incorporate recessed galvanised steel mesh inserts. Supporting bearers are softwood structural grade timber, precision machined and pressure treated to an "internal use standard". Softwood top boards are available as an alternative.



MAIN AIR DUCTS

Constructed from either hardwood or softwood frames with glued and nailed plywood gussets. Cladding is hardwood faced plywood. They are assembled on site and fixed to a concrete floor with steel brackets and anchor bolts.



INTERNAL FAN ROOMS

Can be incorporated into the main air duct either at ground level or on top of the duct to minimise the building size and costs.

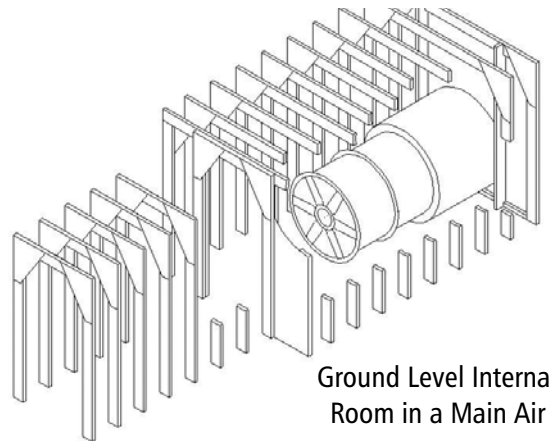

Ground Level Internal Fan Room in a Main Air Duct



Full site assembly allows fle

SPECIALIST PRODUCTS

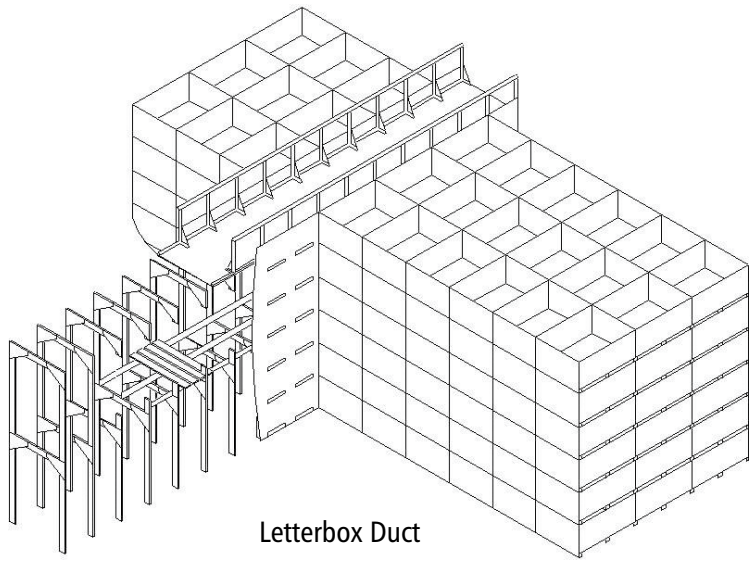

LETTERBOX DUCTS / SUCTION WALLS

Individually designed to meet the requirements of the particular crop and site, these are generally used for potatoes, onions and flower bulbs, incorporating controlled ventilation for drying, cooling and refrigeration. The frames, constructed from Keruing hardwood, are spaced to suit the client's box size and layout and incorporate internal walkways for access to the individual air outlet control doors.

Other products available from Lingward include:

SELF SHEDDING WALLING

POST & PANEL DIVIDING WALLS

DOORWAY BARRIERS

PORTABLE "L" & "T" RETAINING WALLS

BELOW FLOOR GRAIN & POTATO LATERALS

CROP STORAGE BOXES

Below Floor
Laterals

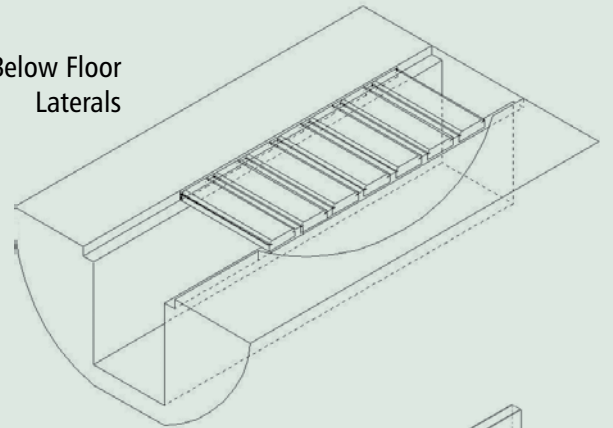

Doorway Barriers

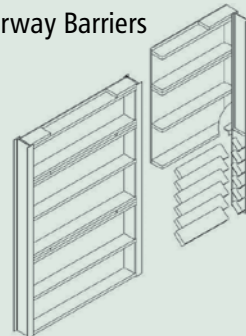

Portable Dividing Wall

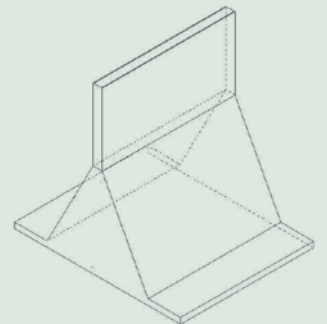

Flexibility of design and easy fitting



LINGWARD
Ipswich Office: 01473 414 371
Mobile: 07776 225 013

Email: sales@lingward.co.uk
Website: www.lingward.com



The Lingward range of products are produced by modern, precision, computer controlled machinery in our factory.

Application of TANALITH E timber preservative into our softwood flooring joists is undertaken in our on-site pressure treatment plants.



HEAD OFFICE:
Unit 7, Old Sawmills Road,
Faringdon, Oxfordshire, SN7 7DS.
Tel: 01367 240091

Lingward is a division of Severn Valley Woodworks Ltd.

